

2 Type

- VL** Clamping arm extended, with slotted hole and with two flanged washers
- VLC** Clamping arm extended, with slotted hole, two flanged washers and clamping screw GN 708.1

Operating principle

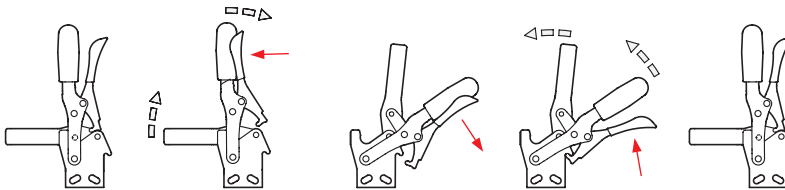

1

Size	F _H in N Holding capacity	a ≈	b ₁	b ₂	b ₃	b ₄	d ₁	d ₂ ≈	h ₁ ≈	h ₂	h ₃	h ₄	h ₅ max.
130	500	67,5	35	10	5	6,3	M 6	5,5	156	41,5	16	25,5	25
230	1000	71,5	43	12	6	8,2	M 8	6,5	183	48	18	30	24

Size	l ₁ ≈	l ₂ ≈	l ₃	m ₁	m ₂	m ₃	m ₄	r ≈	w Adjustable range
130	164	121	55	12,5	19	6,5	7,5	158	17,5
230	198	145,5	68	19,5	19,5	6,5	6,5	191	20

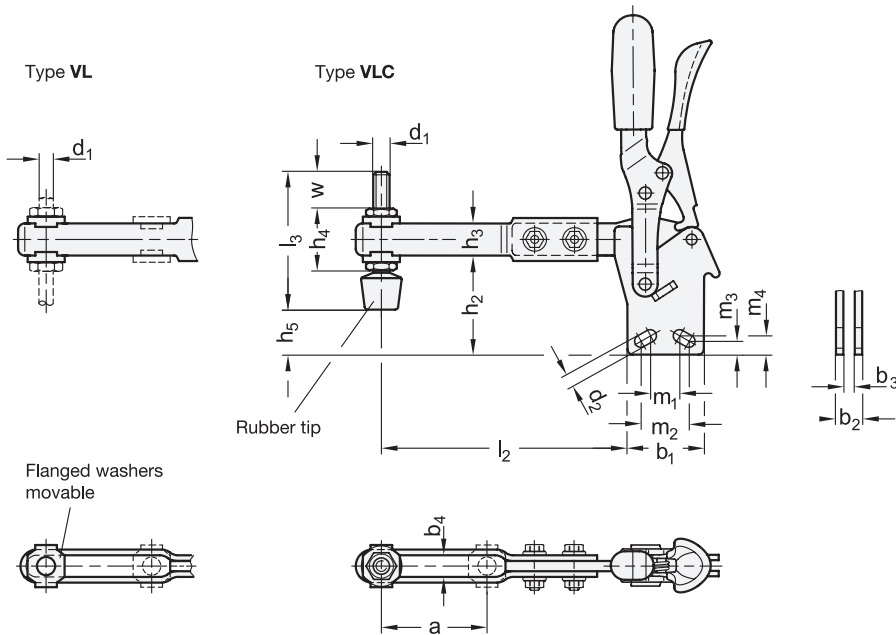

Specification

- Steel
 - Case-hardened steel C10 zinc plated, blue passivated
 - Bearing pins tempered
 - Bearing rivets case-hardened
- All moving parts lubricated with special grease
- Hand grip
 - High quality, oil resistant, red plastic
- Clamping screw GN 708.1, type A
 - Steel, zinc plated
 - Rubber tip 85 Shore A
- RoHS

Accessory

- Clamping screws → Page 585 ff.
- Holders for clamping screws GN 801 → Page 590
- Clamping arm extenders GN 801.1 → New products
- Clamping arm extenders GN 801.2 → New product

Information

GN 810.4 toggle clamps are latched in both end positions. In the clamped position, this prevents unintentional opening or opening caused by vibrations; and in the open position, it prevents self-closing of the toggle clamp, such as due to an extended clamping arm. The latching can be disabled with a single hand to allow for opening / closing.

They work according to the toggle principle: lever and clamping bar move in the same direction. In the clamped position the operating lever is in its vertical position.

Toggle clamps in the U-bar version with two flanged washers (type VL) can accommodate an application specific clamping screw. A clamping screw with neoprene rubber tip is also included for type VLC.

see also...

- General information for toggle clamps → Page 500
- Toggle clamps GN 910.1 („Longlife“) → Page 508
- Toggle clamps GN 810.3 (with horizontal mounting base, with extended clamping arm) → New products

How to order

GN810.4-230-VLC

1	Size
2	Form

