

- 1
- 2
- 3
- 4
- 5
- 6
- 7
- 8
- 9
- 10
- 11
- 12
- 13
- 14
- 15

MATERIAL

Glass-fibre reinforced polyamide based (PA) technopolymer, black colour, matte finish.

CLOSING CAP

Polyamide-based (PA) technopolymer, RAL 7035 grey colour, push-fit assembly.

STANDARD EXECUTIONS

- **MZD-A**: black-oxide steel boss, threaded blind hole.
- **MZD-p**: black-oxide steel threaded screw, chamfered flat end UNI 947 : ISO 4753 (see Technical data).

SPECIAL EXECUTIONS ON REQUEST

Clamping element with threads and different lengths of stud.



ELESA Original design

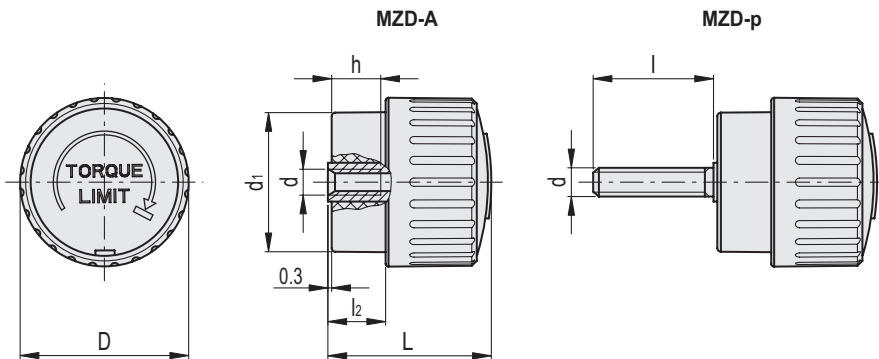

MZD-A

Code	Description	D	d6H	L	d1	l2	h	△△
35501	MZD.50-A-M6	47	M6	44	39	15	12	75
35502	MZD.50-A-M8	47	M8	44	39	15	12	74

MZD-p

Code	Description	D	d6g	L	d1	l	l2	△△
35511	MZD.50-p-M6x30	47	M6	44	39	30	15	82
35521	MZD.50-p-M8x40	47	M8	44	39	40	15	86

FEATURES AND APPLICATIONS

The knob MZD incorporates a mechanism (ELESA patent) which, screwing clockwise until locking, reaches the required torque value by releasing it from the clamping element (boss or threaded screw).

The knob is used when the applied tightening torque must not exceed a certain value.

The torque transmission from the knob to the clamping element occurs by means of a spring system that prevents the set torque from being exceeded. By rotating counterclockwise, the knob unlocks.

The maximum torque value that may be achieved in the clamping operation can be adjusted between 0.2 and 1 Nm (see table "Inclined planes").

The knob has been tested up to 60000 tightening cycles and the values of the torque were unchanged.

TORQUE ADJUSTMENT

1. Remove the cap by inserting a screwdriver in the special slot.
2. The factory setting of the knob is 0.5 Nm. To increase or decrease the torque value, axially change the position of the disc with graduations by moving the center screw by means of a hexagonal key (ch = 2.5). The torque value is read on the small inclined plane which is at the level of the disc in correspondence with the reference notch.
3. Re-fit the cap by inserting it into its seat with a slight pressure.

Inclined planes	
	Torque Nm
Fig.1	0.2 – 0.4 (± 0.1Nm)
Fig.2	0.5 – 0.7 (+0.2 Nm)
Fig.3	0.8 – 1.0 (+0.3 Nm)

