

- 1
- 2
- 3
- 4
- 5
- 6
- 7
- 8
- 9
- 10
- 11
- 12
- 13
- 14
- 15
- RH

MATERIAL

Transparent polyamide based (PA-T) technopolymer. Highly resistant to shocks, solvents, oils with additives, aliphatic and aromatic hydrocarbons, petrol, naphtha, phosphoric esters.
Avoid contact with alcohol or detergents containing alcohol.

SCREWS, NUTS AND WASHERS

Zinc-plated steel.

PACKING RINGS

Step-shaped for the seal on the reservoir walls and NBR synthetic rubber O-ring screw underhead.
Roughness of the packing ring application surface Ra = 3 µm.

FLOAT

Glass-fibre reinforced polyamide based (PA) technopolymer, black colour, with a built-in magnetic element to activate the electric contact when the float reaches the contact threshold located at about 50 mm above the axis of the lower nut (data referred to mineral oil type CB68, according to ISO 3498, temperature 23°C).

SENSOR BRACKET

Watertight in glass-fibre reinforced polyamide based (PA) technopolymer, black colour, with a built-in relay (reed) with two conductors (NO and NC versions) at the output or three connectors (SW version).
For a correct assembly see Warnings.

SWIVELLING CONNECTOR

With built-in cable gland and contact holder. Front or axial output (high or low) ensuring protection against water sprays (protection class IP 65 according to table IEC 529).

CONTRAST SCREEN

White lacquered aluminium. The housing, in the appropriate external rear slot, guarantees the best protection from direct contact with fluid. It can be taken out from the inclined side, before assembly to allow the insertion of level lines or words.

STANDARD EXECUTIONS

- HCV-E-NO: with electric contact normally open (NO).
- HCV-E-NC: with electric contact normally closed (NC).
- HCV-E-SW: with change-over electrical contact (SW).

MAXIMUM CONTINUOUS WORKING TEMPERATURE

90°C (with oil).

FEATURES AND PERFORMANCES

The column level indicator HCV-E, in addition to the visual control, generates an electric signal when the oil level drops to a minimum. Ultrasound welding to guarantee a perfect seal.
Thanks to the side output of the connector, HCV-E level indicator allows to minimise the level of intervention of the sensor.
Maximum fluid level visibility even from side positions.
Lens effect for a better visibility of the fluid level.

TECHNICAL DATA

In laboratory tests carried out with mineral oil type CB68 (according to ISO 3498) at 23°C for a limited period of time, the weld stood up to 18 bar.
For use with other fluids and under different pressure and temperature conditions, please contact ELESA Technical Department.
In any case we suggest to verify the suitability of the product under the actual working conditions.

SPECIAL EXECUTIONS ON REQUEST

- Level indicators for use with fluids containing alcohol.
- UV resistant transparent technopolymer indicators.



ELESA Original design

FUNCTIONING OF THE MIN LEVEL ELECTRICAL SENSOR

- HCV-E-NO: the electrical contact closes on reaching the minimum level.
- HCV-E-NC: the electrical contact is opened when it reaches the minimum level.
- HCV-E-SW: change-over electrical contact: the contact switches between the two terminals.

Electrical features	MIN level sensor
Tension feed	AC/DC
Electric contacts	NO normally open
	NC normally closed
	SW change-over contact
Maximum applicable voltage	NO: 140 Vac, 200 Vdc
	NC: 140Vac, 150 Vdc
	SW: 140Vac, 150 Vdc
Maximum commutable opening capacity	1 A
Maximum bearable opening capacity	NO: 1.2A
	NC: 2A
	SW: 2A
Maximum commutable power	NO: 10 Va
	NC: 20 Va
	SW: 20 Va
Cable gland	Pg 7 (for cables in sheath with Ø 6 or 7 mm)
Conductors cross-section	Max. 1.5 mm ²

Do not mount this indicator in proximity to magnetic fields.

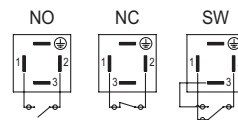

CONNECTOR ASSEMBLY INSTRUCTIONS

1. Remove the connector from the indicator by unscrewing the set screw placed on the connector, take the contact holders out and loosen the cable gland.
2. Slip on the cable into the connector (standard connector) and connect the wires to the terminals 1 and 2 (NO and NC version) or 1,2 and 3 (SW version) of the contact holder.
3. Assemble by pressing the contact holder into the connector in the required position.
4. Screw the connectors to the indicator and then tighten the cable glands.

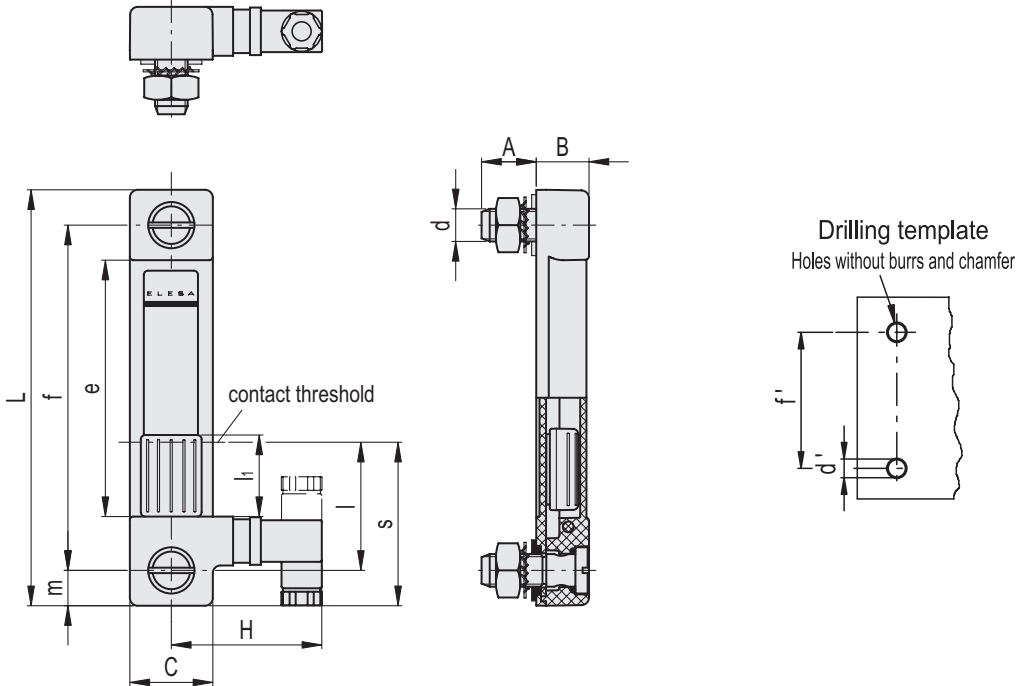
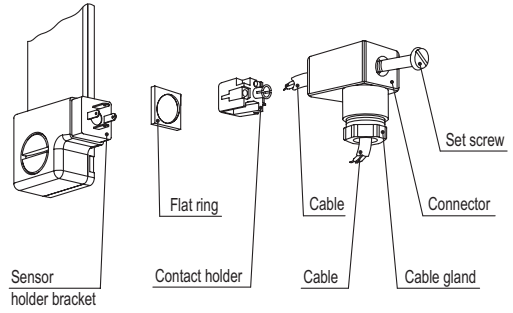

Code	Description	f	d	A	B	C	H	L	e	l	l1	m	s	d'-0.2	f±0.2	C# [Nm]	△
11131	HCV.127-E-NO-M12	127	M12	20	19.5	30.5	55	153	97	50	30	13	63	12.5	127	12	153
11132	HCV.127-E-NC-M12	127	M12	20	19.5	30.5	55	153	97	50	30	13	63	12.5	127	12	153
11133	HCV.127-E-SW-M12	127	M12	20	19.5	30.5	55	153	97	50	30	13	63	12.5	127	12	153

Maximum tightening torque.

