

Range extended!

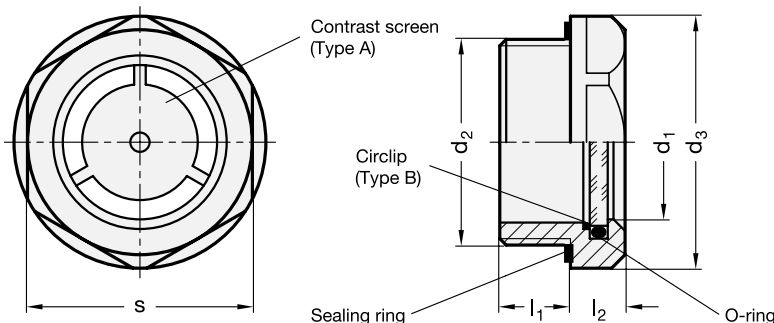

EDELSTAHL Rostfrei
Inox
Stainless Steel

- 3 Type**
- A** with contrast screen
 - B** without contrast screen



1 d ₁	2 d ₂		d ₃	l ₁	l ₂	s
11	G 3/8	M 16 x 1,5	22	8	7,5	20
14	G 1/2	M 20 x 1,5	26	8,5	7,5	23
18	G 3/4	M 26 x 1,5	32	9	8	30
24	G 1	M 33 x 1,5	40	11	8,5	36
32	G 1 1/4	M 42 x 1,5	50	12	9	46

Specification

- Body
Stainless Steel AISI 303
- Contrast screen (Type A)
Technopolymer (Polysulfan)
- Circlip (Type B)
Stainless Steel AISI 301
- **GN 743.4**
 - temperature resistant up to **100° C**
 - Sight glass Float-glass
 - Sealing ring rubber NBR (Perbunan®)
- **GN 743.5**
 - temperature resistant up to **180° C**
 - Sight glass ESG-glass
 - Sealing ring rubber FPM (Viton®)
Identification by not black finish of the sealing ring
- *Elastomer characteristics* → Page 330
- *Stainless Steel characteristics* → Page 334
- **RoHS compliant**

On request

- EPDM seal

Information

Stainless Steel-Oil level sight glasses GN 743.4 / GN 743.5 offer genuine glass of high stability and scratch proof. The sealing is achieved with an O-ring on the **periphery** and not on the face edge of the glass. Leak tightness is therefore not affected by axial pressures.

The outside diameter of these oil level sight glasses with recessed hexagon is chosen to match mounting holes for tube connections according to DIN 3852.

The seal is housed in a groove and it can therefore not be lost. In addition, this groove prevents the seal from being extruded when the sight glass is tightened.

Stainless Steel-Oil level sight glasses GN 743.4 / GN 743.5 can be used on pressurised oil tanks. Tests regarding maximum pressure are available on request.

see also...

- *Oil level sight glasses GN 743 / GN 743.1 (Alu-Body)* → Page 275
- *Oil level sight glasses GN 743.2 / GN 743.3 (Brass-Body)*
→ Main Catalogue Page 903

Stainless Steel-Oil level sight glass	1 d ₁
1 2 3 GN 743.4-14-G1/2-A	2 d ₂
	3 Type

Stainless Steel-Oil level sight glass	1 d ₁
1 2 3 GN 743.5-24-G1-B	2 d ₂
	3 Type