

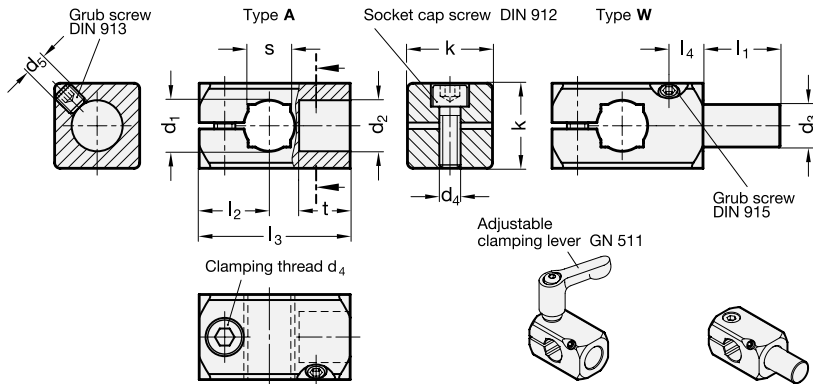

Range extended!



**3** Type  
**A** with bore  
**W** with bolt

<b>1</b> $d_1$ Bore B for shaft tol. h11	<b>2</b> $d_2$ Type A	<b>2</b> $d_3$ Type W	k	$d_4$ Clamping thread	$d_5$	$l_1$	$l_2$	$l_3$	$l_4$	t	s Square V	Clamping lever for $d_4$  Distance sleeve
B 8	B 8	8	16	M 4	M 4	16	13	26	5,5	8	-	GN 511-M4-16
B 10	B 10	10	20	M 5	M 5	17	15,5	31,5	7	10	8	GN 511-M5-20
B 12	B 12	12	20	M 5	M 5	19	16,5	35,5	8	12	10	GN 511-M5-20
B 15	B 15	15	25	M 6	M 6	21	20	43,5	10	15	12	GN 511-M6-25
B 16	B 16	16	25	M 6	M 6	24	20	45	11	16	-	GN 511-M6-25
B 20	B 20	20	30	M 6	M 6	26	22	51	12	18	16	GN 511-M6-30

**Specification**

- Aluminium
  - matt, slide ground **MT**
  - anodized, black **ELS**
- Bolt (Type W)  
Stainless Steel AISI 303
- Socket cap screw DIN 912  
Stainless Steel AISI 304
- Grub screw DIN 913 (Type A)  
Stainless Steel AISI 304
- Grub screw DIN 915 (Type W)  
Stainless Steel AISI 304
- Adjustable clamping levers GN 511
  - Zinc die casting
  - Inserts / Distance bushings  
Stainless Steel AISI 303 → Page 301
- Stainless Steel characteristics → Page 334
- RoHS-compliant

**4** Information

The T-Clamp mountings GN 476 (Type W) are an alternative to twistable two-way clamp mountings GN 475 if high angular forces are required.

The standard version of the clamping screw is a socket cap screw with hexagonal socket DIN 912. It can be replaced by an adjustable clamping lever GN 511 (see table of dimensions).

see also...

- Retaining rods / tubes GN 480.1 → Main Catalogue Page 1085

T-Clamp mounting	<b>1</b> $d_1$
	<b>2</b> $d_2$
<b>GN 476-B12-B12-A-MT</b>	<b>3</b> Type
	<b>4</b> Finish

T-Clamp mounting with bolt	<b>1</b> $d_1$
	<b>2</b> $d_3$
<b>GN 476-B12-12-W-ELS</b>	<b>3</b> Type
	<b>4</b> Finish