

3 Type

- B** without rest position
- C** with rest position

1 **2**

d ₁ Plunger h6	l ₁	l ₂ Stroke	l ₃	b	d ₂	d ₃	d ₄	k	l ₄	l ₅	l ₆	Spring load in N ≈	
												initial	end
6	18	9	9	13	23	4,3	34	23	45	6	25	6	25
6	24	9	15	13	23	4,3	34	23	45	6	25	6	25
8	20	10	10	16	28	5,5	38	26	51	8	27	8,5	28
8	26	10	16	16	28	5,5	38	26	51	8	27	8,5	28
10	24	12	12	16	28	5,5	38	26	51	8	27	9,5	38
10	32	12	20	16	28	5,5	38	26	51	8	27	9,5	38

Specification

- Steel
 - blackened
 - Plunger hardened and ground
- Knob
 - Plastic (Polyamide PA)
 - black, matt
 - not removable
- Load rating information → Page 1463
- ISO-Fundamental tolerances → Page 1479
- Plastic characteristics → Page 1483
- RoHS compliant

Information

Indexing plungers GN 817.3 realize a reasonable priced precision locating when guide bushings DIN 172 / DIN 179 are used.

The precise location is, therefore, not dependent on the guide pin in the plunger, but on the accuracy of the guide bushing (bore tolerance F7) and the plunger (tolerance h7). Both components are hardened and ground. It goes without saying that the bushing length also influences the accuracy of the positioning.

Type C is used for such applications where the plunger has to stay in its retracted position. To achieve this, the knob is rotated by 90° degrees after being retracted. A notch keeps the plunger in this position.

see also...

- Construction and assembly instructions → Page 682
- Range of indexing plungers → Page 640 ff.
- Guide bushings DIN 172 / DIN 179 (cylindrical, with / without collar)
 - Page 683
- Guide bushings DIN 172 .1 / DIN 179.1 (conical, with / without collar)
 - Page 683

How to order

GN817.3-10-24-C

1	d ₁
2	l ₁
3	Type

Construction and assembly instructions for indexing plungers GN 817.3 (Indexing pin cylindrical)

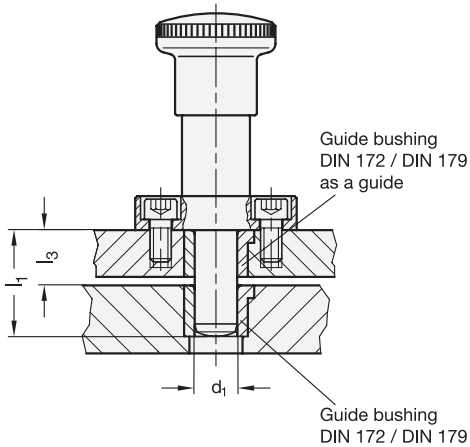

Two different plunger pin lengths l_1 are available for each indexing plunger diameter d_1 .

The length l_3 must ensure that the indexing pin fully disengages, bushing length and plate thickness plus any gap can then be selected within certain margins.

For mounting bushings with tolerance n6, a hole with tolerance H7 corresponding to the external diameter is usually provided.

A selection of suitable guide bushings DIN 172 and DIN 179 is given below on.

see also...

- Indexing plungers GN 817.3 (Plunger pin cylindrical)

→ Page 680

Construction and assembly instructions for indexing plungers GN 817.5 (Indexing pin conical)

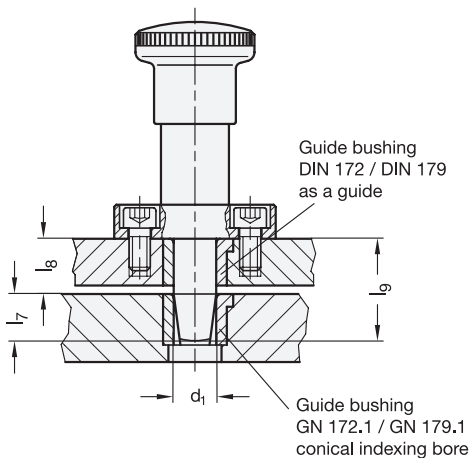

The length l_7 is determined by the penetration depth of the indexing pin into the cone of the bush.

The length l_8 must ensure that the indexing pin fully disengages, bushing length and plate thickness plus any gap can then be selected within certain margins.

If engaged, the pin must have a minimum remaining stroke of 0,5 mm to make sure that the conical section of the pin is located without clearance in the cone of the guide bushing.

Two different plunger pin lengths l_1 are available for each indexing plunger diameter d_1 (see product table).

For a safe remaining stroke length: $l_8 = l_1 - 0,5 \text{ mm}$

For mounting bushings with tolerance n6, a hole with tolerance H7 corresponding to the external diameter is usually provided.

A selection of suitable guide bushings DIN 172 / DIN 179 with cylindrical bore and guide bushings GN 172.1 / GN 179.1 with conical bore is given below on.

see also...

- Indexing plungers GN 817.5 (Indexing pin conical)

→ Page 681