

Range
extended!

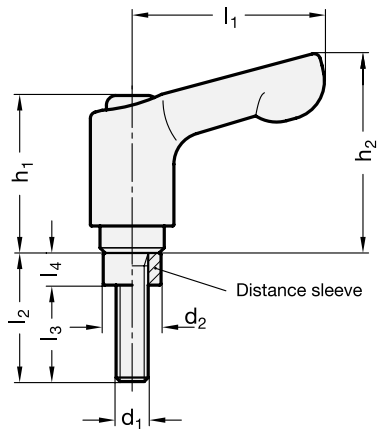

1

2

d ₁	l ₂	d ₂	l ₁	l ₃	l ₄	h ₁	h ₂
M 4	14	7,5	30	9,5	4,5	24,5	30,5
M 4	16	7,5	30	11,5	4,5	24,5	30,5
M 4	20	7,5	30	15,5	4,5	24,5	30,5
M 5	16	9	30	10	6	24,5	30,5
M 5	20	9	30	14	6	24,5	30,5
M 5	25	9	30	19	6	24,5	30,5
M 6	20	10,5	45	13,5	6,5	24,5	35
M 6	25	10,5	45	18,5	6,5	24,5	35
M 6	30	10,5	45	23,5	6,5	24,5	35
M 6	32	10,5	45	25,5	6,5	24,5	35

Specification

- Handle
Zinc die casting
plastic coated
silver, RAL 9006, textured finish
- Insert / Distance bushing
Stainless Steel AISI 303
- *Stainless Steel characteristics* → Page 334
- **RoHS-compliant**

Information

For clamp mountings, the clamping kits GN 511 replace the hexagon socket screw DIN 912. It is used on all clamping points where repeated clamping actions are required, e.g. for adjusting a stop mechanism.

The matching clamping kits for each clamping thread are listed in the dimensional tables of the clamp mountings.

How to order

GN 511-M5-25

1 d₁

2 l₂