

Crank handles



• Material

Glass-fibre reinforced polyamide based (PA) technopolymer. Resistant to solvents, oils, greases and other chemical agents.

• Colour

Black, matte finish.

• Self-adhesive front plate

Anodised aluminium.

• Standard executions

- **MT.**: with revolving handle I.601+x in technopolymer, black colour, matte finish. Black-oxide steel hub, H9 blind hole or H7 reamed pass-through hole.

- **MT-AS**: with revolving handle I.601+x in high-resilience polypropylene based (PP) technopolymer, black colour, matte finish. Black-oxide steel boss with H9 square pass-through hole.

MT.50-AS H9 square pass-through hole with brass reinforcement.

- **MT+IR**: with fold-away handle IR.602 in technopolymer, black colour, matte finish. Black-oxide steel hub, H9 blind hole or H7 reamed pass-through hole.

Features and applications

The reticular structure of the crank arm and the technopolymer used make this handle very strong and therefore suitable for transmitting high torque values.

Accessories on request

Axial retaining washer type GN 184.

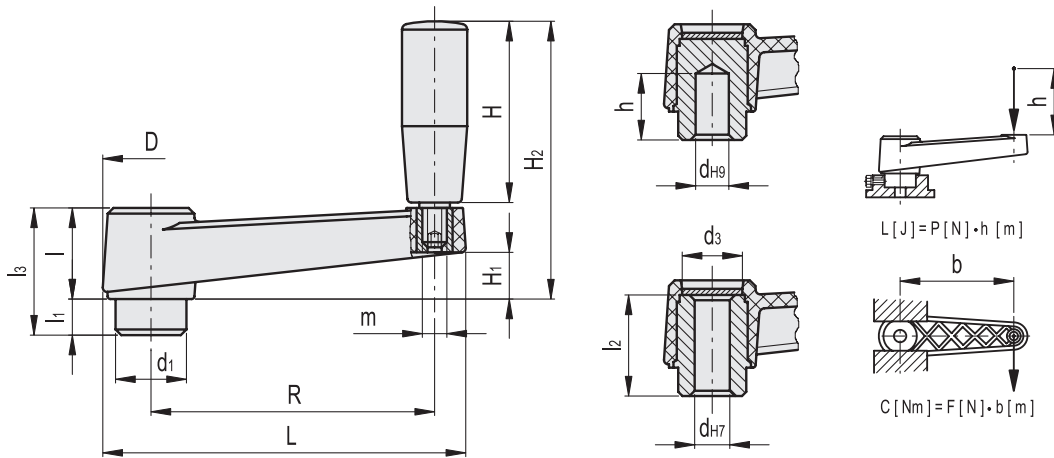

MT.

Code	Description	R	dH7	dH9	L	D	d1	d3	l	l1	l2	l3	h	H	H1	H2	m	C# [Nm]	L# [J]	⚖️
44051	MT.50 A-6	50	6	-	69	23	16	13	21	10	28	31	-	28	10	49	-	60	7	65
44091	MT.64	64	-	6	86	27	18	16	23	10	29	33	18	40	10	63	M6	120	11	100
44101	MT.64 A-8	64	8	-	86	27	18	16	23	10	29	33	-	40	10	63	M6	120	11	95
44102	MT.64-A10	64	10	-	86	27	18	16	23	10	29	33	-	40	10	63	M6	120	11	93
44191	MT.80	80	-	6	105	30	22	17	26	10	32	36	26	50	13	76	M6	180	15	145
44201	MT.80 A-10	80	10	-	105	30	22	17	26	10	32	36	-	50	13	76	M6	180	15	130
44291	MT.100	100	-	8	128	34	24	21	30	10	37	40	28	65	15	96	M8	200	27	240
44301	MT.100 A-12	100	12	-	128	34	24	21	30	10	37	40	-	65	15	96	M8	200	27	225
44391	MT.130	130	-	10	162	40	28	25	35	14	44	49	30	80	20	115	M8	350	45	345
44401	MT.130 A-14	130	14	-	162	40	28	25	35	14	44	49	-	80	20	115	M8	350	45	310
44491	MT.160	160	-	10	198	45	34	27	40	15	49	55	30	90	23	130	M10	450	55	495
44501	MT.160 A-16	160	16	-	198	45	34	27	40	15	49	55	-	90	23	130	M10	450	55	435
44601	MT.210	212	-	12	252	50	40	31	45	15	53	60	30	90	26	136	M10	950	80	705

For maximum applicable torque (C) and impact strength (L) see Technical data.



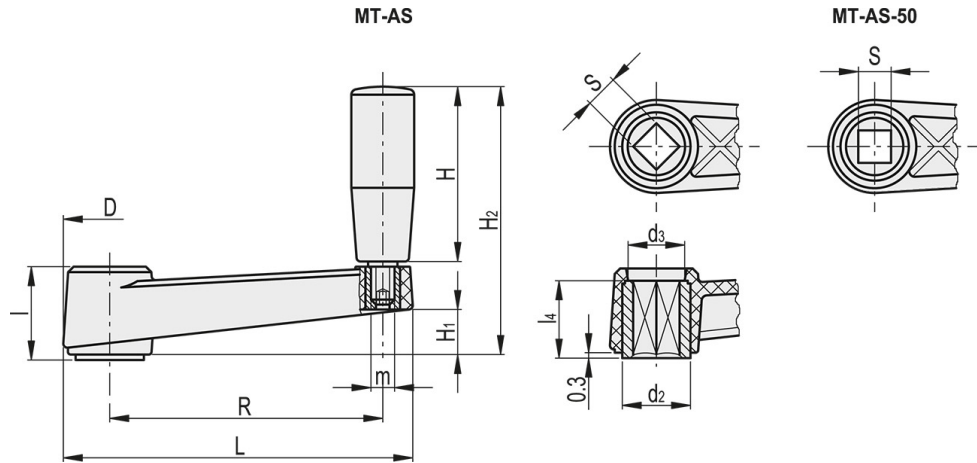

MT-AS

Code	Description	R	S _{H9}	L	D	d ₂	d ₃	l	l ₄	H	H ₁	H ₂	m	C# [Nm]	L# [J]	⚖
44052	MT.50 AS-6x6	50	6	69	23	-	13	21	18	28	10	49	-	60	7	35
44111	MT.64 AS-8x8	64	8	86	27	18	16	23	19	40	10	63	M6	120	11	78
44211	MT.80 AS-10x10	80	10	105	30	20	17	26	22	50	13	76	M6	180	15	105
44311	MT.100 AS-12x12	100	12	128	34	25	21	30	27	65	15	96	M8	200	27	190
44411	MT.130 AS-14x14	130	14	162	40	28	25	35	30	80	20	115	M8	350	45	255
44511	MT.160 AS-17x17	160	17	198	45	30	27	40	34	90	23	130	M10	450	55	335

For maximum applicable torque (C) and impact strength (L) see Technical data.

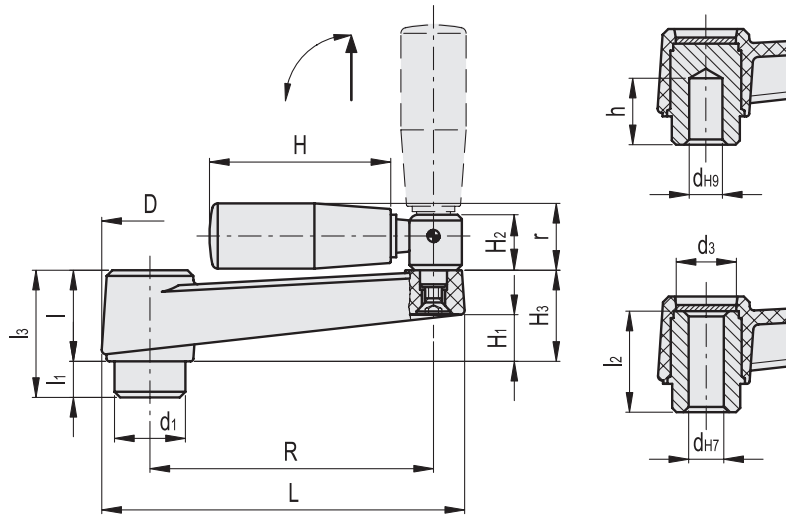

MT+IR

Code	Description	R	d _{H7}	d _{H9}	L	D	d ₁	d ₃	l	l ₁	l ₂	l ₃	h	H	H ₁	H ₂	H ₃	r	C# [Nm]	L# [J]	⚖
44216	MT.80+IR	80	-	6	105	30	22	17	26	10	32	36	26	56	13	15	27	19	180	15	177
44221	MT.80+IR A-10	80	10	-	105	30	22	17	26	10	32	36	-	56	13	15	27	19	180	15	163
44316	MT.100+IR	100	-	8	128	34	24	21	30	10	37	40	28	65	15	20	31	22	200	27	285
44321	MT.100+IR A-12	100	12	-	128	34	24	21	30	10	37	40	-	65	15	20	31	22	200	27	265
44416	MT.130+IR	130	-	10	162	40	28	25	35	14	44	49	30	65	20	20	35	22	350	45	385
44421	MT.130+IR A-14	130	14	-	162	40	28	25	35	14	44	49	-	65	20	20	35	22	350	45	340
44516	MT.160+IR	160	-	10	198	45	34	27	40	15	49	55	30	80	23	20	40	24	450	55	525
44521	MT.160+IR A-16	160	16	-	198	45	34	27	40	15	49	55	-	80	23	20	40	24	450	55	473
44621	MT.210+IR	212	-	12	252	50	40	31	45	15	53	60	30	90	26	23	46	27	950	80	840

For maximum applicable torque (C) and impact strength (L) see Technical data.