

Range extended!

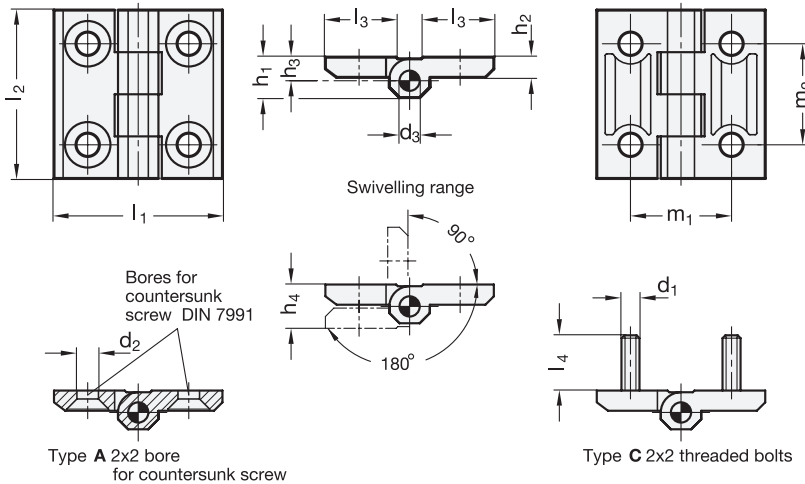

ROSTFREI Rostfrei
Inox
Stainless
Steel

4 Form

- A 2x2 bores for countersunk screws
- C 2x2 threaded bolts

2 3

I ₁	I ₂	Material						d ₁	d ₂	d ₃	h ₁	h ₂	h ₃	h ₄ +0,5	l ₃	l ₄	m ₁	m ₂
		Type A			Type C													
30	30	ZD	NI	A4	AL	-	-	4,3	3	7,5	4	4,5	8,5	10,7	-	18	18	
40	40	ZD	NI	A4	AL	ZD	M 5	5,3	4	9	5	5,5	11	16	12	25	25	
50	50	ZD	NI	A4	AL	ZD	M 6	6,4	6	11,5	6	6,5	13	21	12	30	30	
60	60	ZD	NI	A4	AL	ZD	M 8	8,3	8	15	8	8,5	17	26	14	36	36	

Specification

1 5

- Zinc die casting **ZD**
plastic coated
black, RAL 9005, textured finish ● **SW**
silver, RAL 9006, textured finish ● **SR**
- Stainless Steel
- German Material No. 1.4308 **NI**
- German Material No. 1.4408 **A4**
- matt blasted **GS**
- Aluminium **AL**
anodized, natural colour ● **EL**
- Pin
- Stainless Steel
German Material No. 1.4305
for ZD and AL
- Stainless Steel
German Material No. 1.4571
for NI and A4
- Threaded bolts (Type C)
Stainless Steel
German Material No. 1.4401
- *Stainless Steel characteristics* → page XYZ
- *Load ratings* → page XYZ
- **RoHS compliant**

Information

- see also...
- *Hinges GN 337 (to be unhinged)* → page XYZ
 - *Hinges GN 238 (adjustable)* → page XYZ

Hinge	1 Material
	2 I ₁
	3 I ₂
GN 237-ZD-60-60-A-SR	4 Type
	5 Finish

Stainless Steel-Hinge	1 Material
	2 I ₁
	3 I ₂
GN 237-A4-40-40-A-GS	4 Type
	5 Finish