

GN 583

Lifting eye nuts (rotating)



• Body

High-tensile forged tempered steel with pink plastic surface coating, 100% electro-magnetic tensile tested to EN 1677.

• Nut

Steel, class 10.9 (tensile strength 1000 N/mm²).

Features

Lifting eye nuts GN 583 are mounted in rotating bearings, allowing the direction of the force action to be adjusted and preventing inadvertent loosening or overturning (as potentially possible in lifting eye nuts DIN 582).

Lifting eye nuts GN 583 offer a high load carrying capacity and they are tested to meet safety standards (safety factor 4).

The rated load carrying capacity listed in the above table is clearly marked on the ring. It applies to the most unfavourable load application of the load types listed opposite.

Lifting eye nuts GN 583 comply with with Mechanical Engineering Directive 2006 / 42 / EG and are BG tested.

The hexagon socket nut cannot be removed from the ring.

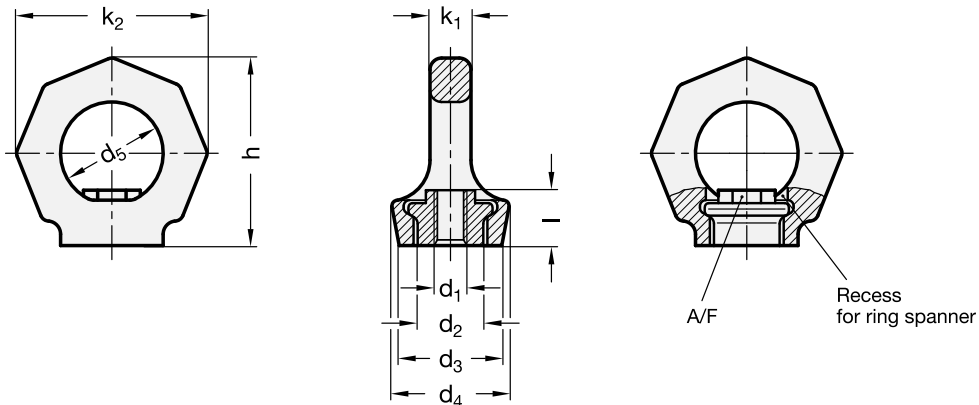

| Standard Elements | Main dimensions | | | | | | | | | | Nominal load | $\frac{\Delta\Delta}{g}$ |
|-------------------|-----------------|----|------|----|----|-----|----|-----|----|----|-----------------|--------------------------|
| | Description | d1 | d2 | d3 | d4 | d5 | h | k1 | k2 | l | | |
| GN 583-M8 | M8 | 16 | 25 | 28 | 25 | 45 | 11 | 47 | 14 | 12 | 0.3 t (3 kN) | 101 |
| GN 583-M10 | M10 | 16 | 25 | 28 | 25 | 45 | 11 | 47 | 14 | 12 | 0.4 t (4 kN) | 110 |
| GN 583-M12 | M12 | 20 | 30 | 34 | 30 | 55 | 13 | 56 | 17 | 14 | 0.75 t (7.5 kN) | 160 |
| GN 583-M16 | M16 | 22 | 35.5 | 40 | 35 | 66 | 15 | 65 | 21 | 19 | 1.5 t (15 kN) | 300 |
| GN 583-M20 | M20 | 29 | 40 | 50 | 40 | 74 | 17 | 75 | 23 | 24 | 2.3 t (23 kN) | 420 |
| GN 583-M24 | M24 | 35 | 50 | 60 | 48 | 90 | 21 | 90 | 29 | 30 | 3.2 t (32 kN) | 770 |
| GN 583-M30 | M30 | 44 | 60 | 75 | 60 | 112 | 26 | 112 | 34 | 36 | 4.5 t (45 kN) | 1480 |

| Load capacity | | | | | | | | | | |
|-----------------------|----------------|--------|----------------|--------|---------------|------------|--------------|-----------|------------|--------------|
| Method of mounting | | | | | | | | | | |
| Number | 1 | 1 | 2 | 2 | 2 | 2 | 2 | 3 and 4 | 3 and 4 | 3 and 4 |
| Angles of inclination | 0° | 90° | 0° | 90° | 0° to 45° | 45° to 60° | asymmetrical | 0° to 45° | 45° to 60° | asymmetrical |
| Factor | 1 | 1 | 2 | 2 | 1.4 | 1 | 1 | 2.1 | 1.5 | 1 |
| M8 | 1.00 t [0.14] | 0.30 t | 2.00 t [0.28] | 0.60 t | 0.42 t [0.10] | 0.30 t | 0.30 t | 0.63 t | 0.45 t | 0.30 t |
| M10 | 1.00 t [0.23] | 0.40 t | 2.00 t [0.46] | 0.80 t | 0.56 t [0.17] | 0.40 t | 0.40 t | 0.84 t | 0.60 t | 0.40 t |
| M12 | 2.00 t [0.34] | 0.75 t | 4.00 t [0.68] | 1.50 t | 1.00 t [0.24] | 0.75 t | 0.75 t | 1.60 t | 1.12 t | 0.75 t |
| M16 | 4.00 t [0.70] | 1.50 t | 8.00 t [1.40] | 3.00 t | 2.10 t [0.50] | 1.50 t | 1.50 t | 3.15 t | 2.25 t | 1.50 t |
| M20 | 6.00 t [1.20] | 2.30 t | 12.00 t [2.40] | 4.60 t | 3.22 t [0.86] | 2.30 t | 2.30 t | 4.83 t | 3.45 t | 2.30 t |
| M24 | 8.00 t [1.80] | 3.20 t | 16.00 t [3.60] | 6.40 t | 4.48 t [1.29] | 3.20 t | 3.20 t | 6.70 t | 4.80 t | 3.20 t |
| M30 | 12.00 t [3.20] | 4.50 t | 24.00 t [6.40] | 9.00 t | 6.30 t [2.30] | 4.50 t | 4.50 t | 9.40 t | 6.70 t | 4.50 t |

Safety instructions

The loads given in brackets refer to the load capacity of the corresponding lifting eye nut DIN 582. If such a value is not indicated the use of the lifting eye nuts DIN 582 is not permitted!

The bolt-on surface for the lifting eye nuts GN 583 must be plane and at a right angle to the threaded borehole. Screwed in, the collar of the nut must make firm contact (do not use washers) and the eye nut must rotate freely by 360°.

Before applying the load, turn the lifting eye nut in the direction of the force. The lifting eye nut is not suitable for frequent rotation cycles under load.

The specified load values apply only in connection with threaded bolts of steel grade > 10.9 if the bolt is turned in over its entire length l . These load values also apply only for a minimum screw-in length of $1.5 \times$ nominal thread diameter in steel with a minimum tensile strength of 37 kp/mm², at an ambient temperature of - 40 °C to + 100 °C. Load-bearing capacity under different conditions upon request.

Operating instructions with more details and specifications are included with every delivery.