

M.1066 BM-CLEAN CLEAN

ELESA Original design

EXTENDED RANGE

Tubular handles (back mounting)



• Tube

Aluminium, epoxy resin coating, glossy finish. Highly resistant to wear and chemical agents. Avoid continuous contact with boiling water or steam.

• Handle shanks

Glass-fibre reinforced polyamide based (PA) technopolymer, matte finish. Resistant to solvents, oils, greases and other chemical agents.

• Tube end caps

Polyamide based (PA) technopolymer.

• Colour

White similar to RAL 9002.

• Standard execution

Special zinc-plated steel screws with threaded blind holes, fitted to the tube by means of brass nuts.

Special executions on request

- Stainless steel tube.
- Different lengths.

Features and applications

This handle, thanks to its white colour and glossy finish, is particularly suitable for applications on medical and hospital equipment and on food processing machines whose parts, for hygienic reasons, must be frequently cleaned. Its solid shape without cavities prevents unhealthy residues from depositing.

Technical data

Tensile stress: F2 values reported in the table are the result of breaking tests carried out with the appropriate dynamometric equipment under the test conditions shown in the figure with ambient temperature.

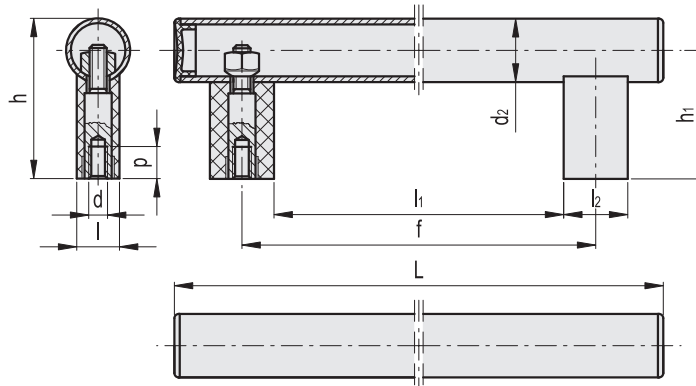
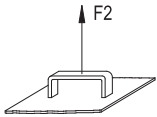

Standard Elements		Main dimensions							Mounting holes		F2 [N]		$\Delta\Delta$	
Code	Description	L	f	h	l	l ₁	l ₂	h ₁	d ₂	d	p _{min}	E #	R #	g
151501	M.1066 BM/30-200 CLEAN	265	200 \pm 1	75	18	170	30	60	30	M8	15	4400	6500	240
151506	M.1066 BM/30-250 CLEAN	315	250 \pm 1	75	18	220	30	60	30	M8	15	3500	6000	260
151511	M.1066 BM/30-300 CLEAN	365	300 \pm 1	75	18	270	30	60	30	M8	15	3300	5700	280
151513	M.1066 BM/30-350 CLEAN	415	350 \pm 1	75	18	320	30	60	30	M8	15	3300	5700	300
151516	M.1066 BM/30-400 CLEAN	465	400 \pm 1	75	18	370	30	60	30	M8	15	2400	4500	320
151521	M.1066 BM/30-500 CLEAN	565	500 \pm 1	75	18	470	30	60	30	M8	15	1500	3800	360
151526	M.1066 BM/30-600 CLEAN	665	600 \pm 1	75	18	570	30	60	30	M8	15	880	3200	380

E = Maximum working load R = Load at breakage (permanent deformation).



ELESA and GANTER models all rights reserved in accordance with the law. Always mention the source when reproducing our drawings.