

GN 873

EXTENDED RANGE

Collar clamps

RoHS

- Material**

Black-oxide steel C45.

- Parts included in the supply**

Guide bushes GN 870 (see page 672).

Features and applications

The collar clamps GN 873 greatly increases the mounting possibilities and, with that, the field of applications for power clamps is vastly increased.

The abutting shoulder can be used for precise positioning of the power clamps thus allowing a problem free exchange of the latter.

The use of the two guide bushes ensures an exact and stable installation of the collar clamp as well as the power clamp.

Other collar clamps for the sizes $d_1=40$ (piston $\varnothing 20$) and $d_1=50$ (piston $\varnothing 40$) are shown under the tube clamp connector range (see separate catalogue of Tube clamp connectors).



MISAJ

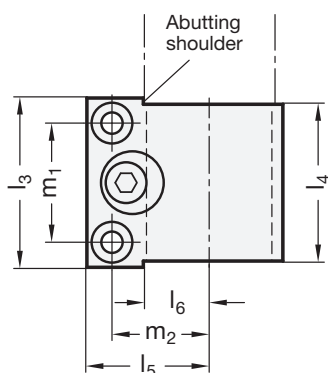
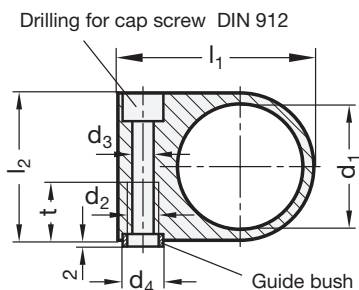

Shaft clamping unit

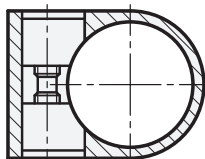

Mounting examples

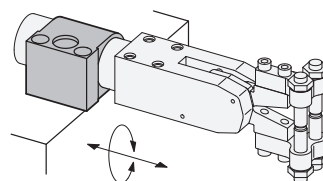
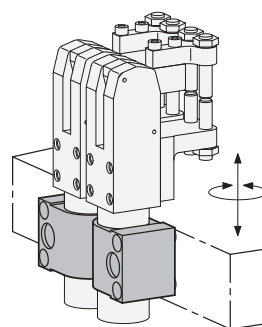

Standard Elements	Main dimensions													\triangle/\triangle
	Description	d1	d2	d3	d4 H8/h6	l1	l2	l3	l4	l5	l6	m1	m2	
GN 873-28	28	M8	6.5	11	52	34	39	36	35	16	26	28.5	14	200
GN 873-40	40	M10	8.5	13	62.5	47	54	51	39	21	38	31	18.5	550
GN 873-50	50	M12	10.5	16	76	58	64	61	47	26	45	37.5	21	1000
GN 873-60	60	M12	10.5	16	86	68	69	66	52	31	50	42.5	18	1100