

DD51

ELESA Original design

Direct drive digital position indicators



EXTENDED RANGE



7
262

Rotary controls

• Base and case

High-resistance polyamide based (PA) technopolymer.
Resistant to solvents, oils, greases and other chemical agents.
Black base.

Case in the following colours:

- **C2**: RAL 2004 orange, glossy finish.
- **C3**: RAL 7035 grey, glossy finish.

On request and for a quantity of at least 10 pieces, it is available in RAL 7021 (C1) grey-black.

The ultrasonically welding between the base and the case prevents separation and avoids dust penetration.

• Window

Transparent polyamide based (PA-T) technopolymer, moulded over the case and with a perfect seal. Resistant to solvents, oils, greases and other chemical agents (avoid contact with alcohol during cleaning operations).

• Display

It indicates the displacement of the mechanism controlled by the spindle from the start position (0).

Four-digit roller counter (three black rolls and one red roll or two black rolls and two red rolls). The digits of red rolls show the decimal values. An additional graduated scale next to the last decimal digit offers further accuracy of reading.

The display can be in different positions (see "Table of the possible combinations").

- **AN**: inclined display, counter in upper position.
- **AR**: inclined display, counter in lower position.
- **FN**: front display, counter in upper position.
- **FR**: front display, counter in lower position.

• Internal gasket

O-ring front sealing in NBR synthetic rubber, between the case and the bushing.

• Rear gasket

Foam polyethylene, supplied.

• Bushing

Black-oxide steel with $\varnothing 14$ mm H7 reamed hole, fitting to shaft by means of a supplied grub screw with hexagon socket and cup end UNI 5929-85.

• Direction of rotation

- **D**: clockwise. Increasing values with clockwise rotation of the bushing.
- **S**: anti-clockwise. Increasing values with anti-clockwise rotation of the bushing.

• Weight

65 grams.

Special executions on request

- AISI 303 stainless steel bushings.
- Special readings after one revolution.
- AISI 303 stainless steel hole reduction sleeves RB51.
- Case in different colours.
- Completely sealed digital position indicators with IP 67 protection class, see IEC 529 table (see catalogue O38, page 503), obtained by means of a brass bushing with double seal ring inside the rear cavity of the base.

Features and applications

Direct drive digital position indicators are suitable on passing through spindles in any position to give direct reading of the positioning of a machine component. They are designed also for motor driven applications (see below "Table of the possible combinations").

Ergonomy and design

Compact roller counter, ergonomically designed digits for rapid reading. The readability of the counter is increased by the magnifying window.

Assembly instructions

1. Drill a $\varnothing 6$ mm by 10 mm hole in the body of the machine with a 22 mm centre distance from the spindle to fit the rear referring pin.
2. Set the spindle to the start or referring position.
3. Fit the indicator with the zeroed roller counter onto the spindle and make sure that the referring pin fit the hole.
4. Clamp the bushing to the spindle by tightening the grub screw with hexagon socket and cup end, according to UNI 5929-85.

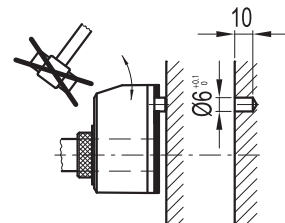

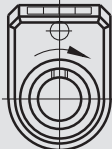









Table of the possible combinations

Display position	Pitch	Reading after one revolution #			Speed (rpm)*	Direction of rotation	Colour
		0 0 1 0	0 0 5 0	0 0 5 0			
		<input type="checkbox"/> Standard readings	<input type="checkbox"/> Readings available on request (min. 10 pieces)				
 inclined upper AN	0.5		00.50	0050	500	 clockwise D	 RAL 2004 C2
	1.0		01.00	0100	250		
	1.0	001.0	00.10	0010	1500		
	1.25	001.2(5)	00.12(5)	0012(5)	1500		
	1.5	001.5	00.15	0015	1500		
	1.57	001.5(7)	00.15(7)	0015(7)	1500		
	1.75	001.7(5)	00.17(5)	0017(5)	1420		
 inclined lower AR	2.0	002.0	00.20	0020	1250	 anti-clockwise S	 RAL 7035 C3
	2.083	002.0(83)	00.20(83)	0020(83)	1200		
	2.5	002.5	00.25	0025	1000		
	3.0	003.0	00.30	0030	830		
	4.0	004.0	00.40	0040	625		
	4.4	004.4	00.44	0044	550		
	5.0	005.0	00.50	0050	500		
 front upper FN	5.7	005.7	00.57	0057	435	 RAL 7021 C1	
	6.0	006.0	00.60	0060	415		
	6.55	006.5(5)	00.65(5)	0065(5)	370		
	7.5	007.5	00.75	0075	330		
	8.0	008.0	00.80	0080	315		
	8.33	008.3(3)	00.83(3)	0083(3)	300		
	10.0	010.0	01.00	0100	250		
 front lower FR	12.0	012.0	01.20	0120	205		
	12.5	012.5	01.25	0125	200		
	15.7	015.7	01.57	0157	150		
	20.0	020.0	02.00	0200	125		

D D 5 1 - AN - 0 0 5 0 - D - C2

The internal mechanism counts also the figures between brackets (even if they do not appear on the display).

* The maximum rotation speed (rpm) of the spindle reported in the table corresponds to a maximum rotation speed of 25000 units per minute of the last roll on the right side of the counter. Rotational speed tests have been performed in our laboratory under standard operating conditions.

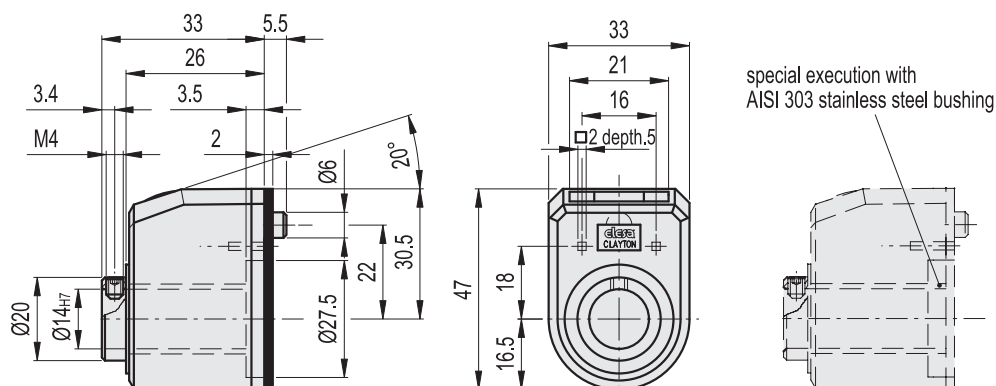

* Complete with colour index, example: CE.84103 DD51-AN-00.50-D-C2

C2 C3
RAL2004 RAL7035

Codes and descriptions of standard combinations

AN (inclined upper)			AR (inclined lower)			FN (front upper)			FR (front lower)		
C2	C3	*	C2	C3	*	C2	C3	*	C2	C3	*
Code	Description		Code	Description		Code	Description		Code	Description	
CE.84103	CE.84101	DD51-AN-00.50-D-	CE.84603	CE.84601	DD51-AR-00.50-D-	CE.85103	CE.85101	DD51-FN-00.50-D-	CE.85603	CE.85601	DD51-FR-00.50-D-
CE.84104	CE.84102	DD51-AN-00.50-S-	CE.84604	CE.84602	DD51-AR-00.50-S-	CE.85104	CE.85102	DD51-FN-00.50-S-	CE.85604	CE.85602	DD51-FR-00.50-S-
CE.84133	CE.84131	DD51-AN-01.00-D-	CE.84633	CE.84631	DD51-AR-01.00-D-	CE.85133	CE.85131	DD51-FN-01.00-D-	CE.85633	CE.85631	DD51-FR-01.00-D-
CE.84134	CE.84132	DD51-AN-01.00-S-	CE.84634	CE.84632	DD51-AR-01.00-S-	CE.85134	CE.85132	DD51-FN-01.00-S-	CE.85634	CE.85632	DD51-FR-01.00-S-
CE.84153	CE.84151	DD51-AN-001.0-D-	CE.84653	CE.84651	DD51-AR-001.0-D-	CE.85153	CE.85151	DD51-FN-001.0-D-	CE.85653	CE.85651	DD51-FR-001.0-D-
CE.84154	CE.84152	DD51-AN-001.0-S-	CE.84654	CE.84652	DD51-AR-001.0-S-	CE.85154	CE.85152	DD51-FN-001.0-S-	CE.85654	CE.85652	DD51-FR-001.0-S-
CE.84161	CE.84159	DD51-AN-001.2/5-D-	CE.84661	CE.84659	DD51-AR-001.2/5-D-	CE.85161	CE.85159	DD51-FN-001.2/5-D-	CE.85661	CE.85659	DD51-FR-001.2/5-D-
CE.84162	CE.84160	DD51-AN-001.2/5-S-	CE.84662	CE.84660	DD51-AR-001.2/5-S-	CE.85162	CE.85160	DD51-FN-001.2/5-S-	CE.85662	CE.85660	DD51-FR-001.2/5-S-
CE.84169	CE.84167	DD51-AN-001.5-D-	CE.84669	CE.84667	DD51-AR-001.5-D-	CE.85169	CE.85167	DD51-FN-001.5-D-	CE.85669	CE.85667	DD51-FR-001.5-D-
CE.84170	CE.84168	DD51-AN-001.5-S-	CE.84670	CE.84668	DD51-AR-001.5-S-	CE.85170	CE.85168	DD51-FN-001.5-S-	CE.85670	CE.85668	DD51-FR-001.5-S-
CE.84183	CE.84181	DD51-AN-002.0-D-	CE.84683	CE.84681	DD51-AR-002.0-D-	CE.85183	CE.85181	DD51-FN-002.0-D-	CE.85683	CE.85681	DD51-FR-002.0-D-
CE.84184	CE.84182	DD51-AN-002.0-S-	CE.84684	CE.84682	DD51-AR-002.0-S-	CE.85184	CE.85182	DD51-FN-002.0-S-	CE.85684	CE.85682	DD51-FR-002.0-S-
CE.84199	CE.84197	DD51-AN-002.5-D-	CE.84699	CE.84697	DD51-AR-002.5-D-	CE.85199	CE.85197	DD51-FN-002.5-D-	CE.85699	CE.85697	DD51-FR-002.5-D-
CE.84200	CE.84198	DD51-AN-002.5-S-	CE.84700	CE.84698	DD51-AR-002.5-S-	CE.85200	CE.85198	DD51-FN-002.5-S-	CE.85700	CE.85698	DD51-FR-002.5-S-
CE.84213	CE.84211	DD51-AN-003.0-D-	CE.84713	CE.84711	DD51-AR-003.0-D-	CE.85213	CE.85211	DD51-FN-003.0-D-	CE.85713	CE.85711	DD51-FR-003.0-D-
CE.84214	CE.84212	DD51-AN-003.0-S-	CE.84714	CE.84712	DD51-AR-003.0-S-	CE.85214	CE.85212	DD51-FN-003.0-S-	CE.85714	CE.85712	DD51-FR-003.0-S-
CE.84233	CE.84231	DD51-AN-004.0-D-	CE.84733	CE.84731	DD51-AR-004.0-D-	CE.85233	CE.85231	DD51-FN-004.0-D-	CE.85733	CE.85731	DD51-FR-004.0-D-
CE.84234	CE.84232	DD51-AN-004.0-S-	CE.84734	CE.84732	DD51-AR-004.0-S-	CE.85234	CE.85232	DD51-FN-004.0-S-	CE.85734	CE.85732	DD51-FR-004.0-S-
CE.84253	CE.84251	DD51-AN-005.0-D-	CE.84753	CE.84751	DD51-AR-005.0-D-	CE.85253	CE.85251	DD51-FN-005.0-D-	CE.85753	CE.85751	DD51-FR-005.0-D-
CE.84254	CE.84252	DD51-AN-005.0-S-	CE.84754	CE.84752	DD51-AR-005.0-S-	CE.85254	CE.85252	DD51-FN-005.0-S-	CE.85754	CE.85752	DD51-FR-005.0-S-
CE.84265	CE.84263	DD51-AN-006.0-D-	CE.84765	CE.84763	DD51-AR-006.0-D-	CE.85265	CE.85263	DD51-FN-006.0-D-	CE.85765	CE.85763	DD51-FR-006.0-D-
CE.84266	CE.84264	DD51-AN-006.0-S-	CE.84766	CE.84764	DD51-AR-006.0-S-	CE.85266	CE.85264	DD51-FN-006.0-S-	CE.85766	CE.85764	DD51-FR-006.0-S-
CE.84277	CE.84275	DD51-AN-008.0-D-	CE.84777	CE.84775	DD51-AR-008.0-D-	CE.85277	CE.85275	DD51-FN-008.0-D-	CE.85777	CE.85775	DD51-FR-008.0-D-
CE.84278	CE.84276	DD51-AN-008.0-S-	CE.84778	CE.84776	DD51-AR-008.0-S-	CE.85278	CE.85276	DD51-FN-008.0-S-	CE.85778	CE.85776	DD51-FR-008.0-S-
CE.84293	CE.84291	DD51-AN-010.0-D-	CE.84793	CE.84791	DD51-AR-010.0-D-	CE.85293	CE.85291	DD51-FN-010.0-D-	CE.85793	CE.85791	DD51-FR-010.0-D-
CE.84294	CE.84292	DD51-AN-010.0-S-	CE.84794	CE.84792	DD51-AR-010.0-S-	CE.85294	CE.85292	DD51-FN-010.0-S-	CE.85794	CE.85792	DD51-FR-010.0-S-

LB with locking device

The DD51-LB position indicators are designed to lock the spindle on which they are mounted to avoid the risk of accidental adjustment alterations due to vibrations. To lock or unlock the spindle rotation, simply move the lever, in pos. A equivalent to locked spindle, in pos. B equivalent to unlocked spindle. Following repeated locking cycles, the special device is highly wear resistant and functions perfectly over time. To order the indicator with spindle locking add the -LB index after the code and description (e.g. CE.84101-LB DD51-AN-00.50-D-GR-LB).

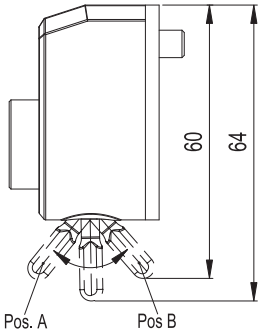

- **GN 954.6**: zinc die-cast bases for spindle locking, epoxy resin coating, black colour, matte finish (see table). Type GN 300 adjustable handle. GN 954.6 locking bases allow an easy and quick locking of the spindles after their positioning. They are equipped with a $\varnothing 6.1$ mm to fit the referring pin of the indicator. They can be assembled with the handle either on the right or on the left and can be fitted to the machine by means of two M4 cylindrical head screws (not included in the supply).

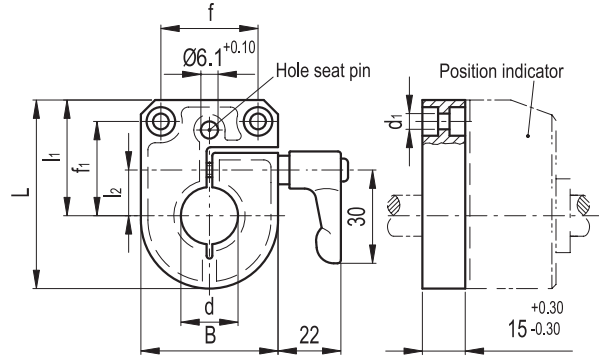

Accessories on request (to be ordered separately)

- **MD51** (see catalogue 038, page 502): polyamide based (PA) technopolymer fluted grip control knob.



- **RB51**: black-oxide steel reduction sleeves (see table).

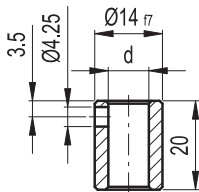

GN 954.6	Main dimensions							Mounting hole	⚖
Description	B	L	d ₁	f	f ₁	l ₁	l ₂	d	g
GN 954.6-33-B8	33	47	4.5	21	23.5	30.5	11	8	84
GN 954.6-33-B10	33	47	4.5	21	23.5	30.5	11	10	83
GN 954.6-33-B12	33	47	4.5	21	23.5	30.5	11	12	82
GN 954.6-33-B14	33	47	4.5	21	23.5	30.5	11	14	81

- **BS51**: glass-fibre reinforced polyamide based (PA) technopolymer spacer plate (code CE.85900).

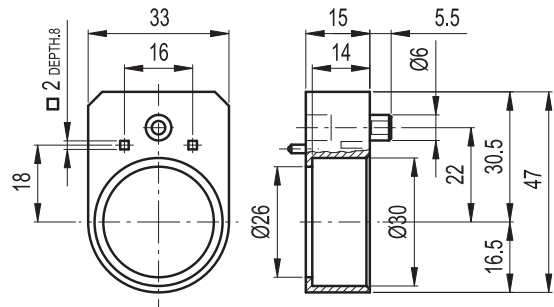

RB51		Mounting hole
Code	Description	d H7
CE.85940	RB51-6	6
CE.85950	RB51-8	8
CE.85955	RB51-10	10
CE.85960	RB51-12	12