

DIN 580 DIN 580-NI

Lifting male eye bolts

• Material

- Execution **ST**: forged steel annealed body, zinc-plated blue passivated, machined contact face.
- Execution **NI**: forged AISI 304 stainless steel annealed body, machined contact face, passivated.

Features and applications

When installing DIN 580 male lifting eye bolts it is of utmost importance to ensure that the face is in firm contact with the mating face. The values indicated in the here-under table are only applicable when the component attached to the ring is in steel, cast steel or cast iron. Side loads across the eye plane are not permitted for safety reasons.

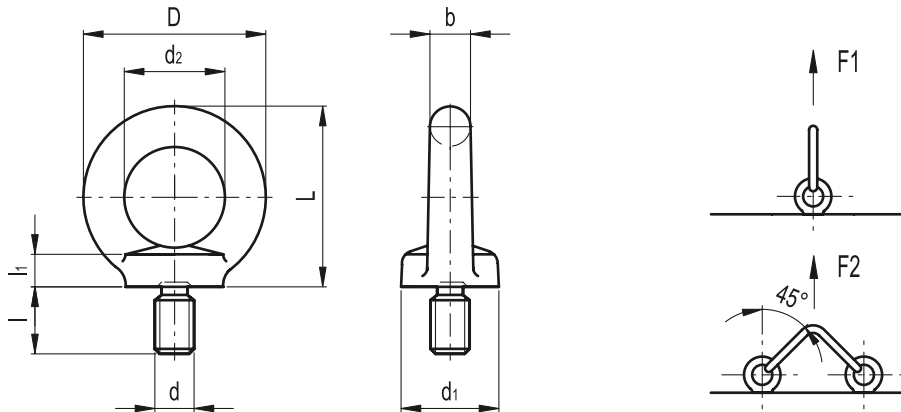

Standard Elements		Main dimensions						Threaded stud		F ₁	F ₂	⚖	
Description	Description	D	L	b	d ₁	d ₂	l ₁	d	l	[N]	[N]	g	g#
DIN 580-M8-ST	DIN 580-M8-NI	36	36	8	20	20	6	M8	13	1400	1000	60	61
DIN 580-M10-ST	DIN 580-M10-NI	45	45	10	25	25	8	M10	17	2300	1700	110	111
DIN 580-M12-ST	DIN 580-M12-NI	54	53	12	30	30	10	M12	20.5	3400	2400	180	182
DIN 580-M16-ST	DIN 580-M16-NI	63	62	14	35	35	12	M16	27	7000	5000	280	283
DIN 580-M20-ST	DIN 580-M20-NI	72	71	16	40	40	14	M20	30	12000	8600	450	455
DIN 580-M24-ST	DIN 580-M24-NI	90	90	20	50	50	18	M24	36	18000	12900	740	747
DIN 580-M30-ST	-	108	109	24	65	60	22	M30	45	32000	23000	1525	-
DIN 580-M36-ST	-	126	128	28	75	70	26	M36	54	46000	33000	2650	-

values for DIN 580-NI



Elesa-GANTER

ELESA and GANTER models all rights reserved in accordance with the law. Always mention the source when reproducing our drawings.